

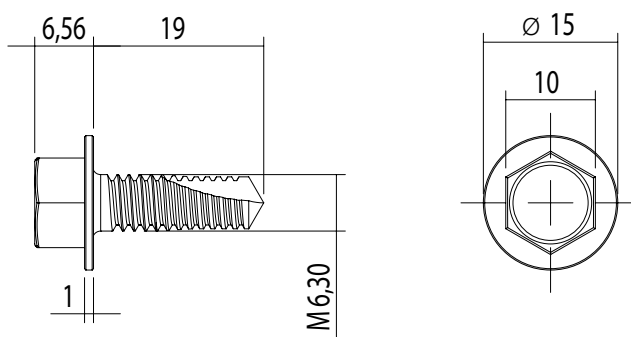

VT1010

Vite autoperforante 6,3x19 zincata | UNI 8117/DIN 7504



Caratteristiche Materiali

Vite: **Acciaio cementato**;

Rivestimento vite: **Zincatura bianca $\geq 5\mu\text{m}$ ISO4042**.

Caratteristiche meccaniche vite a rottura

Trazione (kN): **18,5**;

Taglio puro (kN): **11,0**;

Torsione (Nm): **16,9**;

Flessione (Nm): **10,0**.