

KFF30-1700

Supporti frangisole preassemblati

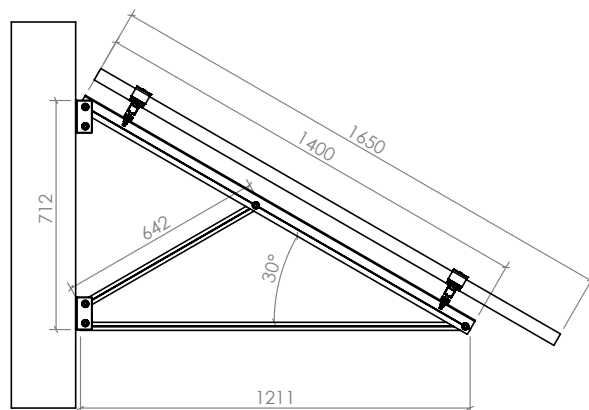

Caratteristiche Materiali

Nomenclatura: **EN AW 6060**;
Trattamento superficiale: **T5**;
Carico di rottura a trazione Rm (Mpa): **230**;
Carico limite di elasticità Rp 0,2 (Mpa): **200**;
Allungamento su 50 mm (%): **12**;
Durezza HB: **72**;
Coefficiente di dilatazione termica lineare tra 20°C e 100°C (1/°K): **23x10⁻⁶**;
Predisposizione al trattamento superficiale di ossidazione: **ottima**.

Caratteristiche Materiali delle staffe

Materiale: **X5 CrNi 18-10 (AISI 304)**;
Forma del prodotto: **C (nastro laminato a freddo)**;
Finitura: **2B (nastro trattato termicamente, decapato, skinpassato)**;
Densità: **7,9 g/m³**;
Resistenza alla trazione: **540 – 750 N/mm²**;
Allungamento: **45 % min.**;
Durezza: **82 HRB**.

Caratteristiche Tecniche

Profili compatibili: **PRT2334, PRT2649, PRT2947**;
Attacco profilo: **inferiore**.

Profili compatibili e rispettive giunzioni

PRT2334-340 3400mm
PRT2334-113 1130mm

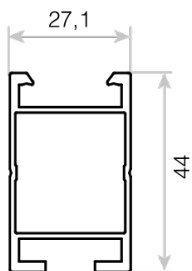

PRL3360

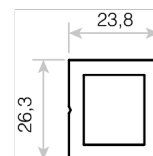

PRT2640-340 3400mm
PRT2640-113 1130mm

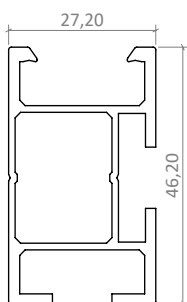

PRG2612

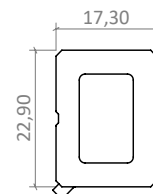
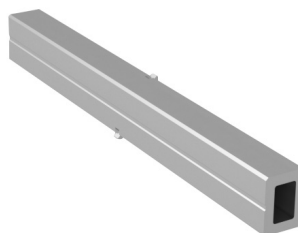

PRT2947-340 3400mm
PRT2947-113 1130mm

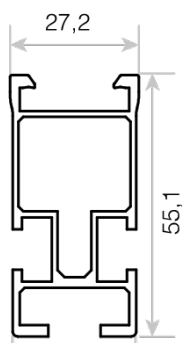

PRL2580

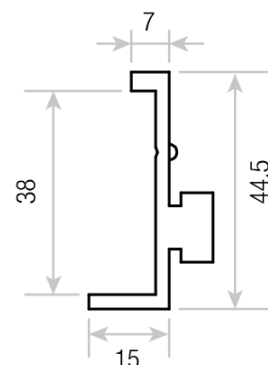

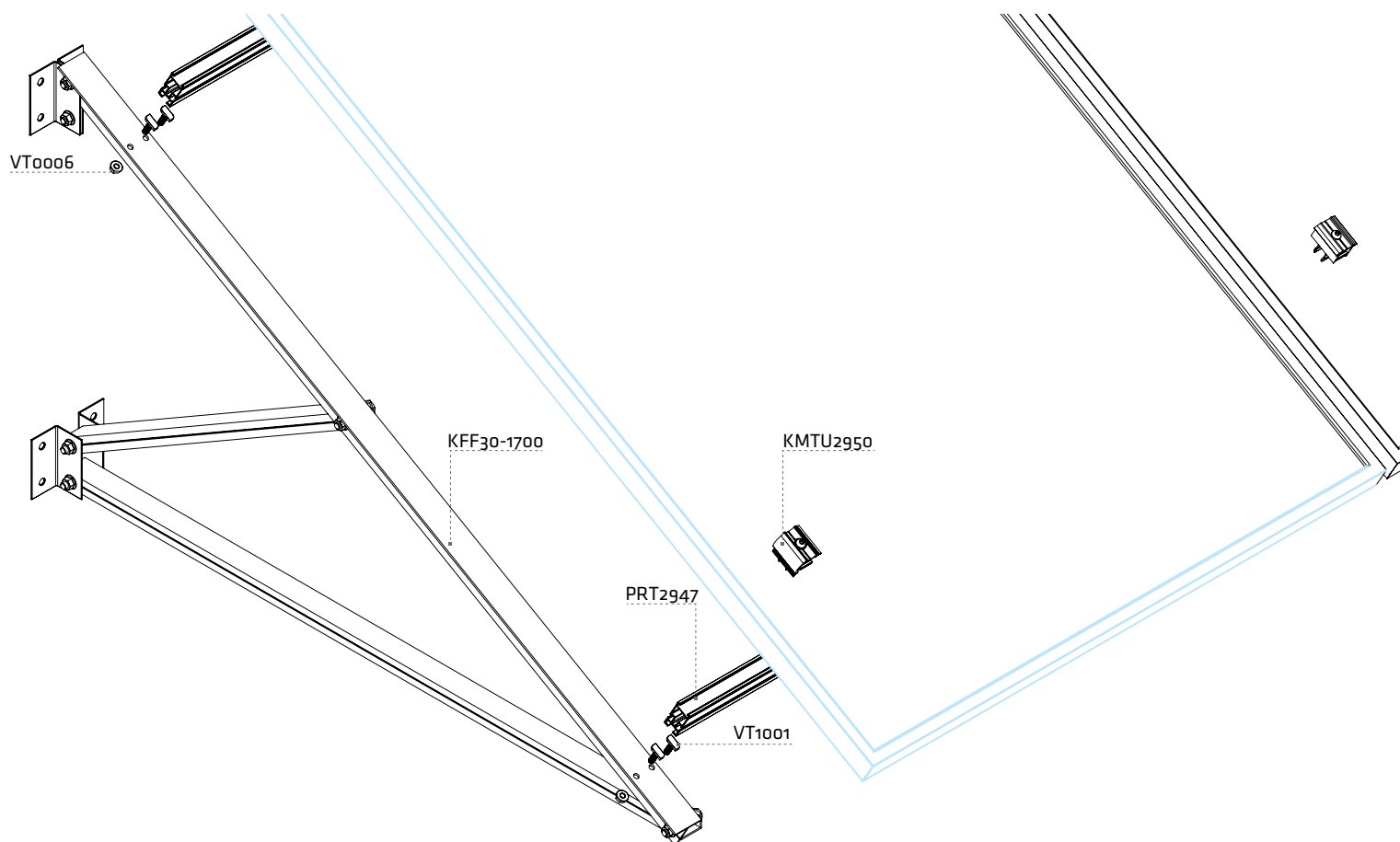

Accessori

KMCU2950
Universale centrale



KMTU2950
Universale terminale



VT1001
Vite testa a martello M8x25



VT0006
Dado flangiato M8

